

FAA APPROVED
PILOT'S OPERATING HANDBOOK AND
FAA APPROVED AIRPLANE FLIGHT MANUAL SUPPLEMENT

FOR
HAWKER BEECHCRAFT MODEL F35, G35
(s/n D-3999 through D-4865)

NORMAL CATEGORY ONLY

Model(s)	NORMAL CATEGORY Operation in excess of:	Or with Fuel in Tip Tanks
F35 G35	2750 lb. Max Gross Weight 2775 lb. Max Gross Weight	

UTILITY CATEGORY

Model(s)	Operation at or less than:	And with Tip Tanks Empty
F35 G35	2750 lb. Max Gross Weight 2775 lb. Max Gross Weight	

REG. NO. _____

SER. NO. _____

This supplement must be attached to the Pilot's Operating Handbook and FAA Approved Airplane Flight Manual when two 20 gallon auxiliary wing tip fuel tanks are installed in accordance with STC(s) SA153EA or SA02722CH. The information contained herein supplements or supersedes the basic handbook only in those areas listed herein. For limitations, procedures, and performance information not contained in this supplement, consult the basic Pilot's Operating Handbook and FAA Approved Airplane Flight Manual.

FAA APPROVED:

Charles L. Smalley, Manager
Chicago Aircraft Certification Office
Federal Aviation Administration
Department of Transportation
Federal Aviation Administration
Des Plaines, IL 60018

Date: _____

LOG OF REVISIONS

Revision	Description	FAA Approved
IR	Original Issue	Mark Anderson May 26, 2009
A	Add STC SA153EA as an applicable STC Add Utility Category eligibility	

SAMPLE

Date: _____

SECTION I GENERAL

This supplement contains revised information for the basic airplane when operated in accordance with STC(S) SA153EA or SA02722CH. The information contained herein supplements or supersedes the basic handbook only in those areas listed herein. Consult the Pilot's Operating Handbook and FAA Approved Flight Manual for limitations, procedures, and performance information not contained herein.

MAXIMUM CERTIFIED WEIGHT

Maximum Ramp Weight.....	2960 lb. for F35, 2985 lb. for G35
Maximum Take-off Weight.....	2950 lb. for F35, 2975 lb. for G35
Maximum Landing Weight	2950 lb. for F35, 2975 lb. for G35

SECTION II LIMITATIONS

GENERAL

The Airplane Flight Manual for this airplane lists information for operation in the UTILITY category. Since the tip tank installation is approved contingent on operation of the airplane in the NORMAL category when operated in excess of 2750 lb. (Model F35) 2775 lb. (Model G35) or with fuel in Tip Tanks, the following Limitations supersede those of the basic Airplane Flight Manual.

This airplane is eligible for operation in accordance with STC(S) SA153EA or SA02722CH and this airplane flight manual supplement only when equipped with the following modifications:

- a) Wing Tip Fuel Tanks (STC(S) SA153EA or SA02722CH)

AIRSPEED LIMITATIONS

Maneuvering Speed (VA)	CAS 109 knots CAS 125 mph
------------------------------	------------------------------

WEIGHT LIMITS

Maximum Ramp Weight.....	2960 lb. for F35, 2985 lb. for G35
Maximum Take-off Weight.....	2950 lb. for F35, 2975 lb. for G35
Maximum Landing Weight	2950 lb. for F35, 2975 lb. for G35

CENTER OF GRAVITY LIMITS (Landing Gear Extended)

FORWARD LIMITS

76.5 inches aft of datum to 2265 lbs. with straight line variation to 83.2 inches at 2950 lbs.
Model F35.

76.5 inches aft of datum to 2265 lbs. with straight line variation to 83.2 inches at 2975 lbs.
Model G35.

AFT LIMITS

84.9 inches aft of datum at all weights.

MANEUVER LIMITS

This is a NORMAL CATEGORY airplane when operated in excess of 2750 lb. (Model F35) 2775 lb. (Model G35) or with fuel in Tip Tanks. Spins and acrobatic maneuvers are prohibited. Normal category airplanes are limited to Non-acrobatic operation.

Non-acrobatic operation includes:

1. Any maneuver incident to normal flying.
2. Stalls (except whip stalls)
3. Lazy eights, chandelles, and steep turns, in which the angle of bank is not more than 60°.

Spins are prohibited.
No inverted maneuvers are approved.

FLIGHT LOAD FACTORS

Positive Maneuvering Load Factors

Flaps Up.....	3.8G
Flaps Down.....	2.0G

FUEL

In addition to the basic airplane fuel system, two auxiliary wing tip fuel transfer tanks are installed with a capacity of 20 gallons each, all of which is usable.

Take-offs are prohibited with more than 1/4 difference in tip tank fuel quantity. During flight if tip tank fuel quantity gauges indicate more than 1/2 tank difference the landing should be made with flaps up.

Date: _____

PLACARDS

In Full View of Pilot:

FUEL CONSUMPTION MAY EXCEED TIP TANK TRANSFER RATE. INITIATE TRANSFER WITH BOTH MAINS AT LEAST ½ FULL. MONITOR MAIN TANK GAUGES TO PREVENT OVERFLOW. TRANSFER TIP TANK FUEL IN LEVEL FLIGHT ONLY.

In Full View of Pilot (Airspeed values are CAS)

NORMAL CATEGORY AIRPLANE
(WHEN OPERATED IN EXCESS OF 2750* LB. MAX. GROSS WEIGHT, OR WITH FUEL IN TIP TANKS)

AIRSPEED LIMITATION (NORMAL CAT. OPERATIONS)

MAXIMUM DESIGN MANEUVERING SPEED 125 MPH (109 KNOTS)

OPERATE IN ACCORDANCE WITH FAA APPROVED FLIGHT MANUAL / PILOT'S OPERATING HANDBOOK. INTENTIONAL SPINS ARE PROHIBITED. NO ACROBATIC MANEUVERS APPROVED.

*Placard is marked 2750 for Model F35
Placard is marked 2775 for Model G35

SECTION II EMERGENCY PROCEDURES

If for any reason it is necessary to land with more than 1/2 tank difference in tip tank quantities, the landing should be made with wing flaps in the "up" position.

Date: _____

SECTION IV NORMAL PROCEDURES

AIRSPEEDS FOR SAFE OPERATION

Maximum Turbulent Air Penetration IAS 108 KTS for F35, 110 KTS for G35
 IAS 124 MPH for F35, 126 MPH for G35

PREFLIGHT INSPECTION

Fuel drains are located on the lower surface of each tip tank. Drain these points daily before the first flight to purge any water from the system.

Check security of flush mounted tip tank filler caps during preflight inspection.

Before flight, check the tip tanks for unsymmetrical fuel loading. If fuel tank capacities differ more than 1/4 tank, relocate fuel prior to take-off.

See Section 7, Systems for additional information.

SECTION V PERFORMANCE

The performance listed in the basic Airplane Flight Manual is applicable to this airplane with the tip tank installation at the gross weight listed in the basic Airplane Flight Manual. Since the certification basis of the tip tank installation does not include a requirement that performance be made available in the AIM, and since the modifier did not choose to supply this information, no performance is listed at gross weights above that of the basic airplane.

SECTION VI WEIGHT AND BALANCE

Weight Condition	Forward CG Limit	Aft CG Limit
2950 lb. for F35, 2975 lb. for G35	83.2	84.9
2265 lb. or less	76.5	84.9

CG Limitations (wheels down)

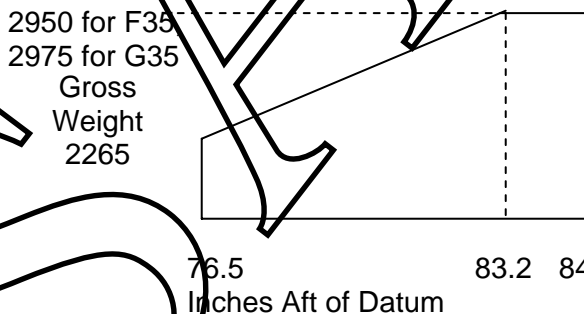

Note:
 CG of Tip Tank Fuel
 Is 87" Aft of Datum

Date: _____

Weight and Balance Loading Form

Model _____ Date: _____

Serial No: D- _____ Reg. No.: _____

Item	Weight	Mom./100
1. Basic Empty Weight		
2. Front Seat Occupants		
3. 3 rd and 4 th Seat Occupants		
4. 5 th and 6 th Seat Occupants		
5. Baggage		
6. Cargo		
7. Sub Total Zero Fuel Condition		
8. Basic Fuel Loading		
9. Tip Tank Fuel Loading		
10. Sub Total Ramp Condition		
11. Less Fuel for Start, Taxi, and Take-off		
12. Sub Total Take-off Condition		
13. Less Fuel to Destination		
14. Landing Condition		

* Fuel for start, taxi, and take-off is normally 10 lb.

Usable tip tank fuel is located at an average arm of 87 inches aft datum.

Date: _____

SECTION VII SYSTEMS DESCRIPTION

FUEL

In addition to the basic airplane fuel system, two auxiliary wing tip fuel transfer tanks are installed with a capacity of 20 gallons each, all of which is usable. Take-offs are prohibited with more than 1/4 difference in tip tank fuel quantity. During flight if tip tank fuel quantity gauges indicate more than 1/2 tank difference the landing should be made with flaps up.

Tip tank fuel is transferred into its respective main tank by an electric pump at a rate of approximately 15 gallons per hour. The transfer pump and a solenoid valve are mounted inside the wheel well of each wing on the rib at wing station 66. At higher power settings, fuel consumption may exceed the fuel transfer rate to the main tank selected.

Tip tank transfer pump switches are located either on the face of the instrument panel or between the front seats on the partition assembly forward of the main spar truss. The pump and solenoid valve circuit breaker is installed adjacent to the pump switches.

A fuel drain is provided on the lower surface of each tip tank.

Fuel quantity is measured by observing the fuel level on a sight gauge located on the inboard side of each tip tank.

Normal tip tank fuel transfer should be accomplished simultaneously to maintain symmetrical wing tip tank fuel loading. Initiate transfer with the left main at 1/2 full and feeding the engine. During the transfer, monitor fuel gauges for both main tanks and stop transfer if gauge indicates full to prevent overflow of fuel through the main tank vent tubes.

SECTION VIII HANDLING, SERVICING AND MAINTENANCE

No Change.

SECTION IX SUPPLEMENTS

No Change.

SECTION X SAFETY INFORMATION

No Change.